

Cambridge University Press

978-0-521-51349-4 - Ecosystem Ecology: A New Synthesis

Edited by David G. Raffaelli and Christopher L. J. Frid

Excerpt

[More information](#)

CHAPTER ONE

The evolution of ecosystem ecology

DAVID G. RAFFAELLI

Environment, University of York

CHRISTOPHER L. J. FRID

*School of Environmental Sciences, University of Liverpool***Introduction**

The sustainable use, management and conservation of ecosystems, as promoted by the Convention on Biological Diversity's Ecosystem Approach (United Nations 1992), and recent initiatives such as the Millennium Ecosystem Assessment (United Nations 2005), emphasise the inter-dependence between ecological systems and human well-being. Healthy social systems demand healthy ecosystems and vice versa. This emergent world view is compelling and persuasive to conservationists, policy makers and managers alike, because it implies win-win solutions for nature conservation and for human development which relies on the continued provision of ecosystem goods and services. Ecosystem management within this context requires a holistic approach that acknowledges the need to work with and across a broad range of natural, physical, social and economic sciences. Whilst there are many successful programmes which have achieved this, mainstream ecologists who have so much to bring to the table have been slow to embrace such approaches. Jones and Paramor (this volume) consider many of the important cultural challenges. The view that humans are part of, not apart from, the biophysical system in which they are embedded has not always sat comfortably with academic researchers, who have traditionally seen their prime focus on, and responsibility to, either the natural system or to broader societal goals, but rarely both. In addition, there are misunderstandings and fears about what holistic ecosystem approaches really are, in turn due to the divergent pathways along which different sections of the ecological community have developed. These issues are not new: the tension between reductionist and holistic approaches has bedevilled the development of a coherent discipline of ecosystem ecology and issues of working across the disciplines recur throughout the short history of ecology.

The aim of this chapter is to describe some of that rocky landscape through which ecosystem ecology and its research community have travelled over the past sixty years or so, from the problems of defining what an ecosystem

Ecosystem Ecology: A New Synthesis, eds. David G. Raffaelli and Christopher L. J. Frid. Published by Cambridge University Press. © British Ecological Society 2010.

Cambridge University Press

978-0-521-51349-4 - Ecosystem Ecology: A New Synthesis

Edited by David G. Raffaelli and Christopher L. J. Frid

Excerpt

[More information](#)

2 DAVID G. RAFFAELLI AND CHRISTOPHER L. J. FRID

actually is in the 1930s, with the only too familiar issues of loose terminology and the all-things-to-all-people concept of an ecosystem. We then provide a retrospective analysis of the most ambitious international ecosystem research programme ever mounted, the International Biological Programme (IBP) of the 1960s and 1970s, an initiative that laid the foundations of ecosystem ecology. We discuss the strengths and weaknesses of the IBP, which have a bearing on how ecosystem ecology might develop in the future. The quantitative holistic approach of systems analysis which underpinned much of the IBP has never achieved the prominence and potential it should have enjoyed and we explore the reasons for this. We then move on to the new emerging frameworks and concepts within Resilience Theory to discuss the potential of this area for ecosystem science and in particular its implications for management. Finally, we reflect on what we can learn from the history of these aspects of the development of ecosystem research so that future endeavours do not result in the same mistakes or ignore the hard lessons learned.

Origins of the concept of the ecosystem

The emerging holistic view of humans and their environment is hardly a novel one: it is fundamental to the human condition and articulated in the articles of faith of many of the world's religions that recognise the inter-connectedness of natural, physico-chemical and human dimensions of the environment. However, the formalisation of the concept of natural ecosystems in a scientific sense began in the early part of the twentieth century, chiefly with the perspectives of Clements and Tansley (for an excellent historical review, see Sheail 1987). Both Clements and Tansley were plant ecologists and their perspectives on natural systems were markedly influenced by the vegetation successional patterns they witnessed around them, although in quite different ways. Clements held that plant communities could be viewed as super-organisms with different developmental stages having their own organic unity. Whether Clements came to this view through his empirical observation of nature (views formed mainly in the environment of the mid west of the US) or whether this perspective was an a-priori concept later supported by empirical observation is difficult to discern at this point in history, given the continual cross-informing of theory and observation in research which all researchers experience. Other leading ecologists of the time, notably Tansley and Gleason (informed mainly by experience of the New England landscape), became increasingly doubtful of this Clementsian world view, taking a more individual-based, reductionist approach, and seeing the patterns in plant communities which develop over time as inevitable expressions of the interactions between individual species, a view that prevails in mainstream ecology to this day. Gleason seems to have suffered greatly for taking what many today would consider a reasonable and sensible stance, becoming one of the first of a long line of 'ecological outlaws' (Sheail 1987), whereas Tansley's status and reputation were seemingly unassailable in this respect.

The 'super-organism' and 'emergent pattern' (broadly equivalent to a holistic versus reductionist) debate took on an uncompromising tone in later years, although Tansley's commentaries and remarks show him to have been surprisingly pluralistic in many respects. He acknowledged that 'the strength of the Clementsian system lay in its philosophical sweep and comprehensiveness' (Sheail 1987, p. 61), holding that ecological concepts were 'creations of the human mind which we impose on the facts of nature' (Tansley 1914, from Sheail 1987, p. 60). In other words, ecological concepts are heuristic devices or semi-abstract models which help to drive the field forward as these devices are explored to their limits, evolve or are overturned (Sheail 1987, p. 63). The Clementsian–Gleason–Tansley debate, which must have seemed bitter at times, is highly relevant in the present context not only because of the outcome of that debate, but also because similar highly charged exchanges, in part based on misunderstandings concerning heuristic devices, occur today, exemplified in the present volume by the schism between reductionist and holistic approaches to ecosystem ecology.

Much of the difficulty in reaching a synthesis towards a unified approach to ecosystem ecology lies in the all-inclusiveness of the term 'ecosystem' (Willis 1997, Jax 2007). Whilst the basic concept has existed in many guises for at least a hundred years, the term itself was used in the 1930s by the British ecologist Roy Clapham and then refined by Tansley in an attempt to impose some rigour and consistency in a rapidly expanding discipline (Willis 1997). Tansley's definition was broad:

the whole system (in the sense of physics), including not only the organism-complex, but also the whole complex of physical factors forming what we call the environment of the biome ... It is the systems so formed which from the point of view of the ecologist are the basic units of nature on the face of the Earth... These ecosystems, as we may call them, are of the most various kinds and sizes. They form one category of the multitudinous physical systems of the universe, which range from the universe as a whole down to the scale of the atom
(Tansley 1935, from Lindeman 1942).

This view of the coupling of the biological and physical-chemical processes to form a single 'ecological system' seemed commonsensical to Tansley and his peers, as it does to most ecologists today. However, today we have additional evidence of the reality of this coupling through the emergent properties of ecosystems, specifically the congruence of the scaling of biological and physical processes in both terrestrial and marine systems. In both environments the rate of change in scale of temporal and spatial dynamics follows the same relationship, i.e. they align on the same slope. Interestingly, marine ecological systems are congruent with the underlying physical scaling, while in terrestrial systems the physical systems operate in a more dynamic manner and the biological responses are slower at each spatial scale. This simple analysis illustrates the close coupling of biological and physical dynamics,

Cambridge University Press

978-0-521-51349-4 - Ecosystem Ecology: A New Synthesis

Edited by David G. Raffaelli and Christopher L. J. Frid

Excerpt

[More information](#)

4 DAVID G. RAFFAELLI AND CHRISTOPHER L. J. FRID

and hence the wisdom of an ecosystem concept that accommodates both, but also highlights fundamental differences in the dynamics of different types of ecosystem.

Since then, the term ecosystem has been conveniently co-opted for a variety of purposes, often to the dismay of those who fear that such looseness reduces the rigour of the science (see commentary by Sheail 1987, pp. 256–7). Most recently, Willis (1997) has offered the following definition: ‘a unit comprising a community (or communities) of organisms and their physical and chemical environment, at any scale desirably specified, in which there are continuous fluxes of matter and energy in an interactive open system’. Willis suggests that the value of such a broad and all-inclusive definition is that the term provides a useful framework for predictive studies, rather than constructing boundaries around an exclusive discipline.

The present-day usage of the term ‘ecosystem’ within initiatives such as the Millennium Ecosystem Assessment (United Nations 2005) and the Ecosystems Approach (United Nations 1992) embraces a much greater swathe of environmental and social science than originally implied by any of the definitions described above (see also Jax 2007, and Haines-Young and Potschin, this volume). In particular, there has been a shift in the view of an ecosystem to one where people are considered part of an interactive holistic system, as opposed to humans being external drivers of change. Interestingly, Tansley’s writings suggest that he would probably have welcomed the broadening of the concept to include human behaviour and the social sciences. Not only does he appear to have been remarkably tolerant of abstractions of nature (exemplified by his tolerance to Clements’ heuristics), as long as they remained useful models for taking the field forward and were not taken past their logical limits, but he also lived and worked in a part of the world (the UK) where the profound influence of human activity and the way humans had shaped the landscape and its vegetation over several thousand years was taken as read, unlike the situation for many ecologists based in the New World.

Holistic frameworks for exploring complex, interacting systems: the contributions of Lindeman and Elton

Ecologists have long acknowledged the awesome complexity of the interacting systems with which they have to deal, and that if commonalities of process and pattern across different ecosystems are to be identified in a search for underlying ‘laws’, then ways of handling this complexity need to be found. At around the middle of the last century, new approaches to tackling this complexity were developing, the most notable of which were Elton’s and Lindeman’s frameworks (Elton 1927, Lindeman 1942). Raymond Lindeman’s seminal paper is breathtaking in its scope and contribution. Published posthumously immediately after the author’s tragically early death, the paper provided what has

Cambridge University Press

978-0-521-51349-4 - Ecosystem Ecology: A New Synthesis

Edited by David G. Raffaelli and Christopher L. J. Frid

Excerpt

[More information](#)

turned out to be an enduring framework that allowed, for the first time, plant and animal communities to be considered together, and which accommodated decomposers and non-living components. By grouping individual species into functional trophic types (primary, secondary, tertiary etc., producers and consumers), Lindeman provided a holistic scheme of considerably reduced complexity compared to the spider-web diagrams of food webs. He developed Elton's earlier descriptions of hierarchies of numbers and body sizes in animal food webs by describing pyramids of biomasses and flows of energy between functional trophic types (trophic levels) that could accommodate all types of organisation. This approach led to explorations of trophic-energy relationships and concepts such as ecological efficiencies which accounted for the limits to food-chain length previously observed by Elton, as well as allowing intriguing observations on the populations of 'vegetarian Chinese' compared to the 'more carnivorous English' that can be supported by a given level of production!

The International Biological Programme

The framework developed by Lindeman was a major step in the development of ecosystem science. It also provided the basis for much of the science that underpinned one of the most imaginative international programmes on ecosystems ever embarked upon: the International Biological Programme (IBP). Whilst little known or appreciated by today's generation of ecologists, this programme established many of the fundamental techniques and approaches that we now take for granted in ecosystem ecology. In addition, the IBP can be seen as the forerunner of those programmes and initiatives which are the focus of the present volume, such as the Millennium Ecosystem Assessment. The IBP was a sequel to the International Geophysical Year (1957–8) and, it has been claimed, partly a response to the rise of the molecular sciences in the 1950s and 1960s which 'posed a strong challenge both in academic status and financial support to the long-established macrobiological sciences and their concern with whole organisms and communities' (Collins and Weiner 1977). The gestation of the IBP is also associated with a recognition following World War II of the need to feed a growing world, particularly in developing countries, a need which in turn demanded a clear scientific understanding of the functioning of ecological systems and the limits to their production (Worthington 1965, 1975, 1983). An ambitious series of site-specific studies was established across the world, covering a great diversity of ecosystem types in over fifty countries. Each explored aspects of the fundamental basis of ecosystem productivity and human adaptation to those systems. Potentially, the programme was truly international, truly interdisciplinary and truly holistic.

The long-term beneficiaries of those research programmes include the editors of this volume and many other ecologists. Most importantly, a systems-analysis approach characterised the research programmes, facilitating

comparisons and the search for commonalities between different ecosystem types (Figure 1.1). Many synthesis volumes and other publications have resulted from the IBP but the programme had a finite life (1964–74) and there probably remains much meta-analysis of the outcomes to be completed, even today. Underpinning the science of the overall programme were the ‘Manuals For’ handbooks, written in order to try to inject a degree of standardisation and comparability between studies, although researchers were never constrained to slavishly adopt these techniques, thus allowing their further development (Worthington 1975). Several of these IBP Manuals (e.g. Eleftheriou and McIntyre 2005) have continued to evolve into the present day, retaining their prime role in describing how to carry out research in particular systems.

An important feature of the IBP that resonates with the present emerging Ecosystem Approach is its inclusion of a social dimension – Human Adaptability. This is perhaps not too surprising given the focus of the programme – the production of food for a growing global human population. However, the linkages and feedbacks between social and ecological systems which characterise frameworks advocated today by, for example, the Millennium Ecosystem Assessment (MA) or the Convention on Biological Diversity (CBD), were not addressed. At the adoption of the Human Adaptability (HA) proposals in the early scoping meetings in the 1960s, ‘a dissident view was voiced by the anthropologist Margaret Mead’ (see Lutkehaus (2008) for a fascinating biography).

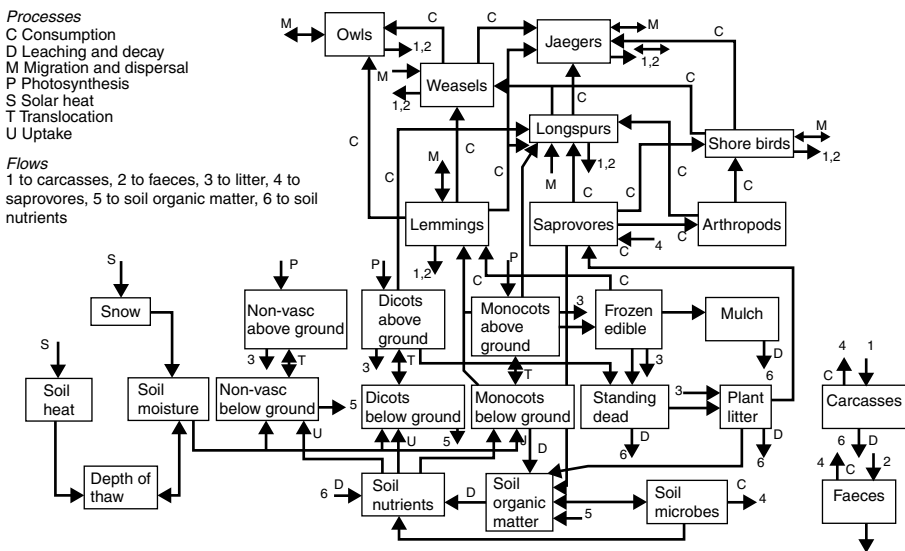

Figure 1.1 Box-and-flow diagram of a tundra ecosystem, Point Barrow, Alaska, typical of the representations used in IBP programmes to illustrate the relationships between key stocks of biomass. Adapted from Worthington (1975).

Cambridge University Press

978-0-521-51349-4 - Ecosystem Ecology: A New Synthesis

Edited by David G. Raffaelli and Christopher L. J. Frid

Excerpt

[More information](#)

'The members listened with deep interest to Dr Mead's long and eloquent plea for the rejection of the HA proposals and the substitution of a programme based on the social sciences' (Collins and Weiner 1977, pp. 5–6). Whilst Mead's arguments are not recorded in detail, they were felt to be outside the scope of the programme and beyond the human biologists present, whose views ultimately prevailed. The Human Adaptation section of the IBP became concerned with surveys of the ability of humans to adapt to their environment in a social anthropology, physiological, genetic and medical sense, in an attempt to understand issues of health and welfare (e.g. growth and physique, genetic constitution, work capacity and pulmonary function, climatic tolerance, nutritional studies, medical and metabolic studies, demographic assessment) (Weiner and Lourie 1969). Whilst some way perhaps from the MEA and the Ecosystem Approach of the CBD, it should be remembered that the interdisciplinary approaches, paradigms and techniques we take for granted today were not as prominent, and in some cases did not even exist, in the 1970s and 1980s. The social dimension never seems to have achieved the emphasis it warranted within the IBP, perhaps because many areas of social science were not as fully developed as they are today or perhaps it was an idea whose time had not yet come.

Recently, the context and legacy of the IBP for current major international initiatives have been ably reviewed by Thomas Rosswall in his address to the British Ecological Society. Here, we restrict our analysis to the views expressed at the time by the US and the UK contributors in the context of what we might learn when designing future initiatives. The US efforts within the IBP dwarfed those of the UK in scale and funding. At its peak, 1,800 US scientists participated in the programme supported by \$57 million in federal funds (Boffey 1976), an astonishing amount even by today's standards. Initially, it proved difficult to engage with all of the research community needed to deliver the programme, but, ironically, the programme suffered in the end from what one of the US planners described as 'ecological sprawl', as individual research studies only marginal to the original science vision signed up to be included under the IBP umbrella (Boffey 1968).

Other reported concerns were the lack of central governance of the science, within the US and for the programme as a whole (*ibid.*). Disappointingly, given the remit of the programme to examine the basis of productivity, agricultural research was largely ignored and, at least in the US, the Human Adaptability studies 'got relatively short shrift because they fell outside NSF's normal vision and the National Institutes of Health weren't interested' (Boffey 1976). Finally, although much was learned by the US ecosystem community as to how to work across the natural and physical sciences, one of the major science objectives, to develop systems-analysis models of ecosystems to assess human impacts and

Cambridge University Press

978-0-521-51349-4 - Ecosystem Ecology: A New Synthesis

Edited by David G. Raffaelli and Christopher L. J. Frid

Excerpt

[More information](#)

predict the effects of natural change ‘largely failed, primarily because the goal was unrealistic in view of the lack of valid theory and experience in dealing with such large and complex systems’ (ibid.).

A similar comment about systems analysis was made by Holdgate (in Worthington *et al.* 1976) in his assessment of the UK programme: the data demanded to construct systems-analysis models were underestimated and the ability to use those data was overestimated. The UK’s assessment (see dedicated issue of *Philosophical Transactions of the Royal Society, series B*, volume 274 (1976)) pointed out other areas which could have developed better: there was too much compartmentalisation within studies and not enough cross-system comparison (Fogg and also Worthington, in Worthington *et al.* 1976); training of ecologists and knowledge exchange and transfer were not thought to have been achieved, especially in developing countries (Waddington and Worthington, in Worthington *et al.* 1976); there was no effective repository for the huge amounts of data collected (Worthington *et al.* 1976).

Reading the various IBP progress reports and post mortems, one is struck by the familiar and contemporary nature of many of the issues identified: the lack of overall programme governance; an unwillingness of some sections to become engaged at the start, and who therefore had little influence on the direction of the science; few plans for data storage and management and for final synthesis; a tendency of groups to work within those ecosystems with which they are most familiar and comfortable; issues of working across the disciplines, especially across the natural and social sciences. These all remain significant issues today for ecosystem ecology and the community needs to work hard to resolve them. Given the experience and lessons of the IBP, there can be no excuse for not anticipating such problems and putting mechanisms in place to deal with them.

Systems-analysis approaches

A major feature of the IBP, including the HA section described above, was the adoption of a systems-analysis approach. Thus, in their synthesis volume of the HA programme, Collins and Weiner (1977) state that ‘The fruitfulness of this strategy – though it is costly in time resources and personnel – is well exemplified by the energy flow models developed in the American Andean project...the system serves to link calorie and nutrient exchanges with other population characteristics – the efficiency of work, the population density and the distribution of human biomass, etc.’ A systems-analysis approach was thus recognised as demanding in resources (cf. appraisals by Boffey (1976) and Holdgate (1976), above), but it was deemed to have the capacity to link biological and social dimensions. Does this approach offer a way forward for prosecuting the Ecosystems Approach research agenda? To assess this we need to

explore the context within which systems-analysis approaches to ecosystem questions have developed.

Many of the IBP programme synthesis volumes and related outputs contain a formal systems analysis, or at least a figurative representation of the major flows and components in a system using 'box-and-flow' diagrams, representing the biomass or state of a variable, and the flows representing inputs and outputs to and from other boxes (Figure 1.1). The degree to which such static representations help us to understand the dynamic nature of the system can be debated (remember, these were before the days of the personal computer or even the hand calculator), but they were helpful in representing the feedbacks and in identifying the major flows of material through the system.

At about the same time as the inception of the IBP, such holistic approaches were becoming familiar to a generation of ecologists through the extremely popular and influential *Fundamentals of Ecology* textbook by Eugene Odum (1953), and later with his brother Howard Odum (1959). H. T. Odum brought to the book his energy flow and thermodynamics approach, later formally presented as systems ecology in Odum (1983). Paul C. Stoy (this volume) provides an excellent account of this area. The brothers adopted a fundamentally holistic approach to their science that not only allowed an appreciation of the sources, sinks and flows of matter between ecosystem components, but also permitted an exploration of higher, ecosystem-level patterns and processes. Central to the school of thought that developed from, in particular, H. T. Odum's research group and associates is how these higher-level attributes change over time as the individual components, and hence the entire system, moves away from thermodynamic equilibrium through increased organisation and complexity of the components. Inevitably, much of the terminology and representation was borrowed from thermodynamic theory, including the notions of work, entropy and exergy. Systems analysis is thus a tool which allows identification of holistic properties of an ecosystem that can be achieved through a variety of applications. In the present ecosystem context, the most widely used are energy flow diagrams (e.g. Odum 1983) and various forms of ecological network analysis based on input-response-output theory (e.g. Patten *et al.* 1976, Ulanowicz 1986, 2000, Fath and Patten 1999).

Other terms and concepts needed to be developed as the science grew, such as ascendancy and energy (see also, Stoy, this volume). Ascendancy expresses the magnitude of the boxes-and-flows in the system (throughput) scaled by system complexity (information content), and has been shown to be a useful measure of ecosystem development state with links to stability (Christensen 1995). The concept of emergy (embodied energy) has been developed by H.T. Odum (Odum 1996, Odum and Odum 2000) and his colleagues (e.g. Costanza 1980) for addressing economic valuation aspects of environmental management and sustainability, so that energy can be represented in monetary terms.

Cambridge University Press

978-0-521-51349-4 - Ecosystem Ecology: A New Synthesis

Edited by David G. Raffaelli and Christopher L. J. Frid

Excerpt

[More information](#)

The holistic approach, language and the use of heuristic devices and concepts such as ecosystem goals and directed development, inevitably set the systems school on a different trajectory from population biology, which is very much a reductionist science (e.g. Mansson and McGlade 1993). The tension between the reductionist and holistic camps has created considerable misunderstandings and misrepresentations, with an often bitter discourse. These different world views are reminiscent of the Clements–Gleason–Tansley debate, and are in part a reflection of different ways in which ecologists have historically approached their science in the UK and in North America. In a moving eulogy to H.T. Odum following his death in 2002, Brown *et al.* (2004) articulated very clearly the central issues. For those who had the privilege of working with Howard Odum, he was clearly an inspirational dynamo of a teacher. The price of being associated with this world view was their vilification and demonisation as ‘Odumites’ who promulgated ‘Odumania’, whilst some saw the holistic approach as somewhat ‘blasphemous...and not to be trusted in a world where reductionism and small-scale biology held rein’ (*ibid.*).

It is perhaps not surprising that the systems approach developed by Odum has been somewhat patchy in its geographical take-up. For instance, in a celebration of the oldest ecological society in the world, the British Ecological Society, and an assessment of the BES’s contribution to the development of ecological ideas (Sheail 1987), Odum and his approach are not mentioned or referenced at all. This is by no means a criticism of John Sheail (his is a superb and comprehensive book), but a true reflection of how the relevance of this area has been perceived by what is a major and influential group of ecologists in the world. Two companion volumes produced by the BES for their jubilee celebration do contain three chapters: Waring (1989) on fluxes of matter and energy, Ulanowicz (1989) on thermodynamic-based approaches to oceans and Paul (1989) on soil processes (Cherrett 1989, Grubb and Whittaker 1989) but even today H.T. Odum’s work and its legacy are not fully appreciated within the UK. The same is not true for other parts of Europe and for North America where, although there is the same reluctance by many ecologists to embrace this field if only as a heuristic device *sensu* Tansley (see above), the influence of Odum’s ideas has been much more pervasive (but see also Stoy, this volume).

Whatever the issues, it is clear that the basic systems approach that Odum and others have advocated, and which the largest ecosystem programme to date, the IBP, embraced, has the potential for exploring the kind of dynamics and behaviour of large-scale systems which have recently come to the interest of policy makers. Many of these potentialities are encapsulated in Jorgensen *et al.* (2007), who have mapped applications of systems-based theory onto a broad variety of ecological areas including island biogeography, optimal foraging theory, niche theory, multipoint stability and diversity gradients. Jorgensen *et al.*